



CUBE VAN, BOX TRUCK & ENCLOSED TRAILER ALUMINUM PRODUCT GUIDE



WHY CHOOSE WESTCAN PRODUCTS?

Westcan Manufacturing is a family-owned and operated business with a focus on creating high quality products which offer great value to you, our customer.

Westcan products are high-quality, affordable, and made to outlast your vehicle. All products are manufactured with precision and care at our primary facility in the Pacific Northwest, then warehoused on-site so that we can provide you with the fastest possible turnaround

time. Do you have any questions about the product or your vehicle? We have a team of excellent customer service representatives available during our operating hours to help you out!

We stand behind the quality of our aluminum van storage solutions. Our commitment to customer satisfaction means you can trust us to deliver top-notch products.

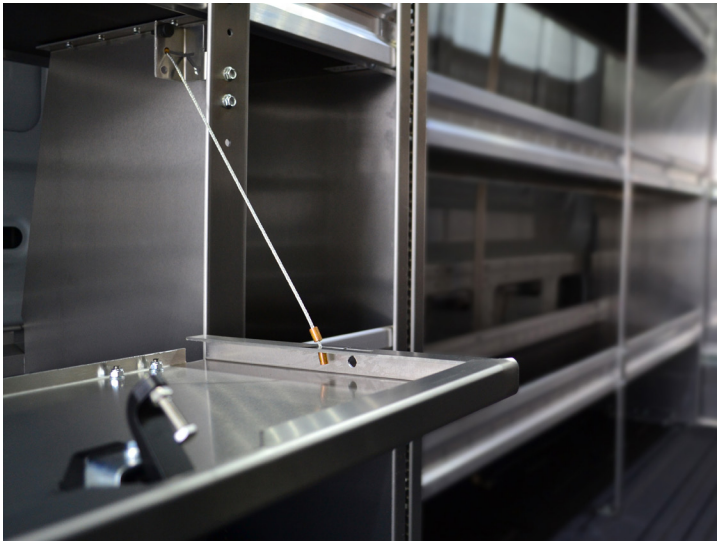

INTRODUCING PACKOUT HOLDERS FOR MILWAUKEE

Revolutionize the way you organize and transport your tools and equipment with Westcan's aluminum **Packout Holders**. Designed in various sizes and configurations exclusively for Milwaukee Packout™ parts, our packout holders offer a seamless integration into your van setup.

With their robust construction and sleek design, the packout holders not only optimize space but also enhance the professional look of your van interior.

No matter the dimensions or layout of your van, we have the perfect solution to optimize your storage space and keep your gear organized.

Whether you're a tradesperson, a DIY enthusiast, or a contractor, Westcan's packout holder storage systems are built to endure the rigors of the job site.

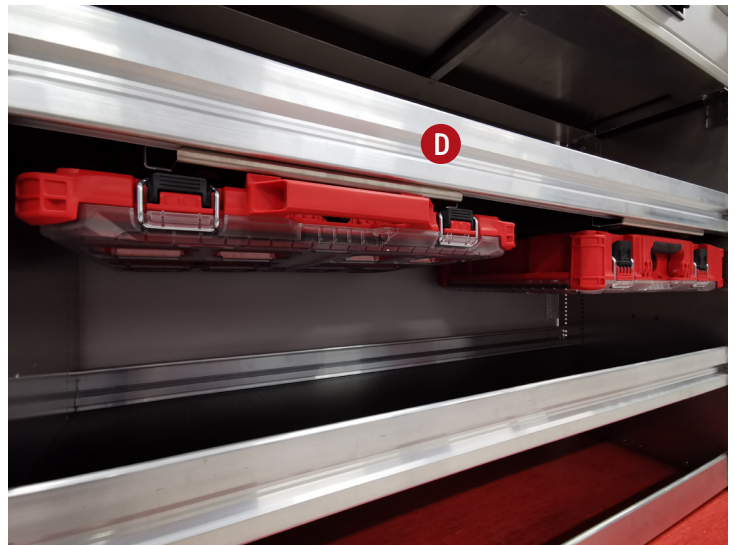

PART #	DESCRIPTION	SIZE
51-6220	A 5 Place Milwaukee Packout Holder	46" H x 20" ³ / ₈ W x 15" D
51-6221	B 4 Place Milwaukee 3 Drawer Packout Holder	62" H x 22 ³ / ₄ W x 16 ¹ / ₂ D
51-6219	C 7 Place Milwaukee Packout Holder	62" H x 20" ³ / ₈ W x 15" D
51-6218	D Single Milwaukee Packout System Shelf & Wall Adapter Plate	14" W x 14" D

ALUMINUM STANDARD SHELVING UNITS – DIVIDERS SOLD SEPARATELY ON PAGE 7



STANDARD SHELVING UNITS FOR CUBE VANS & TRAILERS

PART #	L	D	H	SHELF QTY	SHELF DEPTHS	PART #	L	D	H	SHELF QTY	SHELF DEPTHS
16-3401	36"	16"	62"	3 Shelves	3 @ 14"	16-3419	36"	18"	62"	3 Shelves	3 @ 18"
16-3402	48"	16"	62"	3 Shelves	3 @ 14"	16-3420	48"	18"	62"	3 Shelves	3 @ 18"
16-3403	60"	16"	62"	3 Shelves	3 @ 14"	16-3421	60"	18"	62"	3 Shelves	3 @ 18"
16-3404	72"	16"	62"	3 Shelves	3 @ 14"	16-3422	72"	18"	62"	3 Shelves	3 @ 18"
16-3405	84"	16"	62"	3 Shelves	3 @ 14"	16-3423	84"	18"	62"	3 Shelves	3 @ 18"
16-3406	96"	16"	62"	3 Shelves	3 @ 14"	16-3424	96"	18"	62"	3 Shelves	3 @ 18"
16-3407	36"	16"	62"	4 Shelves	4 @ 14"	16-3425	36"	18"	62"	4 Shelves	4 @ 18"
16-3408	48"	16"	62"	4 Shelves	4 @ 14"	16-3426	48"	18"	62"	4 Shelves	4 @ 18"
16-3409	60"	16"	62"	4 Shelves	4 @ 14"	16-3427	60"	18"	62"	4 Shelves	4 @ 18"
16-3410	72"	16"	62"	4 Shelves	4 @ 14"	16-3428	72"	18"	62"	4 Shelves	4 @ 18"
16-3411	84"	16"	62"	4 Shelves	4 @ 14"	16-3429	84"	18"	62"	4 Shelves	4 @ 18"
16-3412	96"	16"	62"	4 Shelves	4 @ 14"	16-3430	96"	18"	62"	4 Shelves	4 @ 18"
16-3413	36"	16"	62"	5 Shelves	5 @ 14"	16-3431	36"	18"	62"	5 Shelves	5 @ 18"
16-3414	48"	16"	62"	5 Shelves	5 @ 14"	16-3432	48"	18"	62"	5 Shelves	5 @ 18"
16-3415	60"	16"	62"	5 Shelves	5 @ 14"	16-3433	60"	18"	62"	5 Shelves	5 @ 18"
16-3416	72"	16"	62"	5 Shelves	5 @ 14"	16-3434	72"	18"	62"	5 Shelves	5 @ 18"
16-3417	84"	16"	62"	5 Shelves	5 @ 14"	16-3435	84"	18"	62"	5 Shelves	5 @ 18"
16-3418	96"	16"	62"	5 Shelves	5 @ 14"	16-3436	96"	18"	62"	5 Shelves	5 @ 18"

All Bin Shelving units come with 12" deep shelves to accept Westcan's Red Bins.

Features & Benefits of Aluminum Shelving Units

- Shelf decks are constructed using a durable 1/2"- thick honeycomb textured phenolic plywood base with extruded aluminum lips
- All aluminum Westcan shelving units are Carb II compliant
- Load rating of 55 lbs per linear foot up to a maximum of 250 lbs per shelf
- Various accessories are available to customize your shelving
- End panel shelf mounting locations are spaced 1/2" apart

Red Plastic Bin Packages

Westcan offers red plastic bin packages designed to fill each 12" deep shelves based on shelf length and bin width. These bins are sold separately – *See page 7 for more info!*

Save Time by Using Your Space Wisely!

Don't waste your time and energy sifting through a messy cargo area to find that one tool you just had!

To avoid headaches and stay organized, shelving is a must. Choose between shelving units that include a two to six shelf count and add on a floor retainer lip so that you can maximize use of your available space.

Need even more shelving? Just order additional shelves to create your perfect fit! All aluminum shelving units come with pre-drilled accessory mounting holes on the end panels so that you can easily install compatible Westcan shelving accessories. *See page 8 for more info!*

BUILD YOUR OWN SHELVING UNIT – BASE COMPONENTS

A – END PANEL KITS (SOLD IN PAIRS)

PART #	D	H	COMPATIBLE SHELVING DEPTHS
16-3007	16"	24"	12", 14"
16-3001	16"	48"	12", 14"
16-3002	20"	48"	18"
16-3003	16"	62"	12", 14"
16-3004	20"	62"	18"
16-3005	16"	72"	12", 14"
16-3006	20"	72"	18"

Did You Know?

Build Your Own Shelving allows for complete flexibility in your shelving design, from shelf count to accessories. You're able to mix bins and dividers from shelf to shelf, add a work top or any other compatible accessories [found on page 8](#) to create shelving that matches your needs perfectly!

All Build Your Own Shelving components come with necessary installation hardware.

B – SINGLE SHELF KITS

	PART #	L	D		PART #	L	D		PART #	L	D
12" D Shelves	31-1224	24"	12"	14" D Shelves	31-1424	24"	14"	18" D Shelves	31-1824	24"	18"
	31-1236	36"	12"		31-1436	36"	14"		31-1836	36"	18"
	31-1248	48"	12"		31-1448	48"	14"		31-1848	48"	18"
	* 31-1260	60"	12"		* 31-1460	60"	14"		31-1860	60"	18"
	31-1272	72"	12"		31-1472	72"	14"		31-1872	72"	18"
	31-1284	84"	12"		31-1484	84"	14"		31-1884	84"	18"
	31-1296	96"	12"		31-1496	96"	14"		31-1896	96"	18"

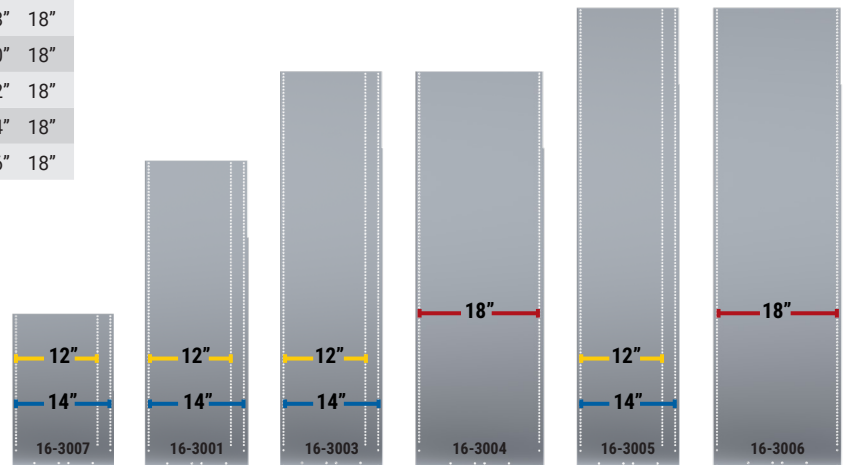
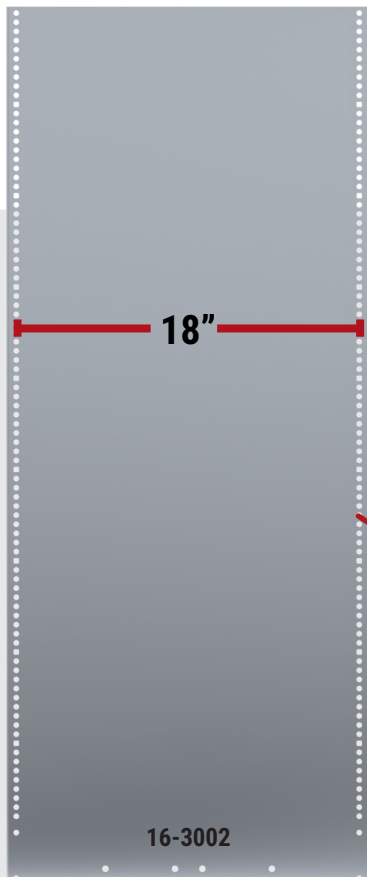

Accessory Mounting Holes

All aluminum universal Westcan end panels come complete with several sets of punched holes useful for quick and easy mounting of accessories such as cylinder mounts, straight and swivel hooks, and literature storage. [See page 8 for more info!](#)

Square Shelf Mounting Holes

Every 10th hole on Westcan's universal end panels are square. This allows you to be able to more easily keep track of your desired mounting points for your shelf decks so that each shelf deck is level upon installation. All shelf mounting holes are spaced 1/2" apart.

BUILD YOUR OWN SHELVING UNIT – ACCESSORIES

C – CENTER SUPPORT KITS

PART #	DESCRIPTION
33-2048	48" H Center Support (Sold in Pairs)
* 33-2062	62" H Center Support (Sold in Pairs)
33-2072	72" H Center Support (Sold in Pairs)

D – RED PLASTIC BIN PACKAGES

12" D Shelves

PART #	W	D	H	DESCRIPTION
33-5001	4 1/8"	11 3/16"	4"	For 12" x 24" Shelves – 5 Pieces
33-5002	4 1/8"	11 3/16"	4"	For 12" x 36" Shelves – 8 Pieces
33-5003	4 1/8"	11 3/16"	4"	For 12" x 48" Shelves – 11 Pieces
* 33-5004	4 1/8"	11 3/16"	4"	For 12" x 60" Shelves – 14 Pieces
33-5005	4 1/8"	11 3/16"	4"	For 12" x 72" Shelves – 17 Pieces
33-5011	4 1/8"	11 3/16"	4"	For 12" x 24" Shelves – 3 Pieces
33-5012	6 5/8"	11 3/16"	4"	For 12" x 36" Shelves – 5 Pieces
33-5013	6 5/8"	11 3/16"	4"	For 12" x 48" Shelves – 7 Pieces
33-5014	6 5/8"	11 3/16"	4"	For 12" x 60" Shelves – 9 Pieces
33-5015	6 5/8"	11 3/16"	4"	For 12" x 72" Shelves – 10 Pieces

E – ALUMINUM DIVIDER KITS

PART #	QTY	COMPATIBLE SHELVING DEPTHS
33-1012	10 Pieces	12" D Shelving
33-1014	10 Pieces	14" D Shelving
* 33-1018	10 Pieces	18" D Shelving

F – WORK BENCH END PANEL KITS (SOLD IN PAIRS)

PART #	D	H	COMPATIBLE SHELVING DEPTHS
22-3009	15"	24"	12" D Shelving
* 22-3005	15"	32"	12" D Shelving
22-3012	15"	36"	12" D Shelving
22-3007	15"	42"	12" D Shelving

G – ALUMINUM & BUTCHER BLOCK WORK TOP KITS

Aluminum

Butcher Block

PART #	L	D	H	DESCRIPTION
60-2415	24"	15"	1 3/4"	24" x 15" Aluminum Work Top
60-3615	36"	15"	1 3/4"	36" x 15" Aluminum Work Top
60-4815	48"	15"	1 3/4"	48" x 15" Aluminum Work Top
60-6015	60"	15"	1 3/4"	60" x 15" Aluminum Work Top
60-7215	72"	15"	1 3/4"	72" x 15" Aluminum Work Top
* 61-2415	24"	15"	1 3/4"	24" x 15" Butcher Block Work Top
61-3615	36"	15"	1 3/4"	36" x 15" Butcher Block Work Top
61-4815	48"	15"	1 3/4"	48" x 15" Butcher Block Work Top
61-6015	60"	15"	1 3/4"	60" x 15" Butcher Block Work Top

Work Top Kits

Work top kits are available in aluminum top that has 1 1/2" of fir plywood for strength or maple butcher block finish, and both come with a 2 3/4" high aluminum back splash, and can also be mounted in shelving units!

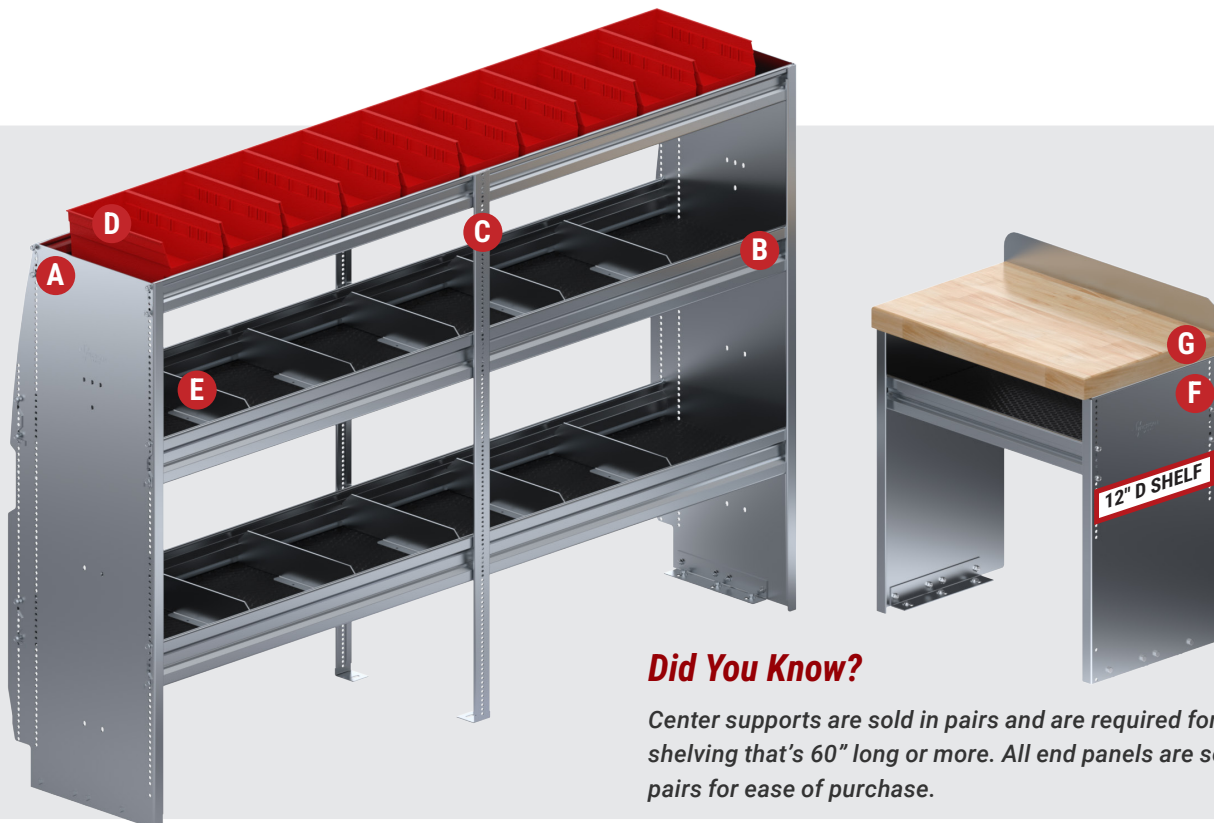

Did You Know?

Center supports are sold in pairs and are required for all shelving that's 60" long or more. All end panels are sold in pairs for ease of purchase.

SHELVING ACCESSORIES

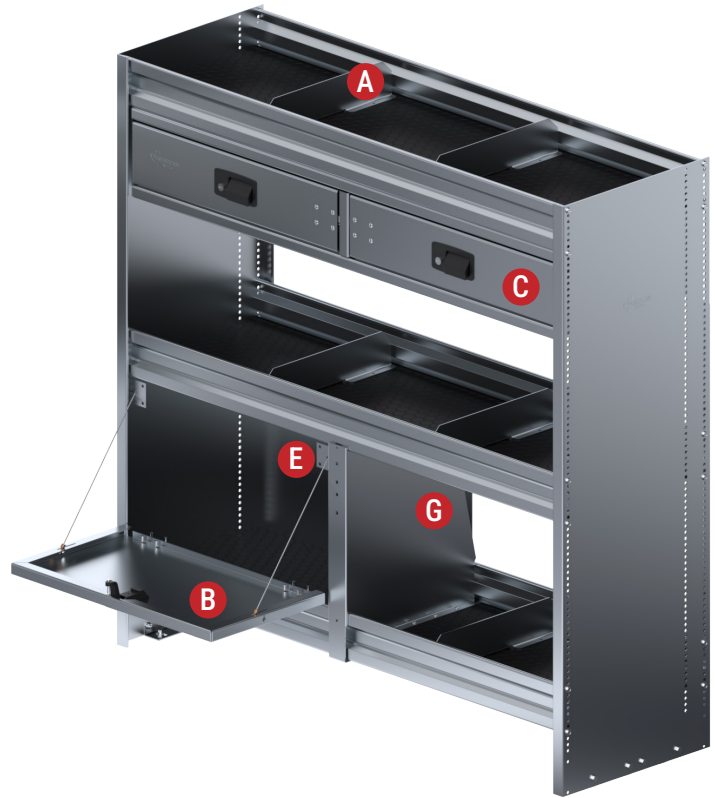
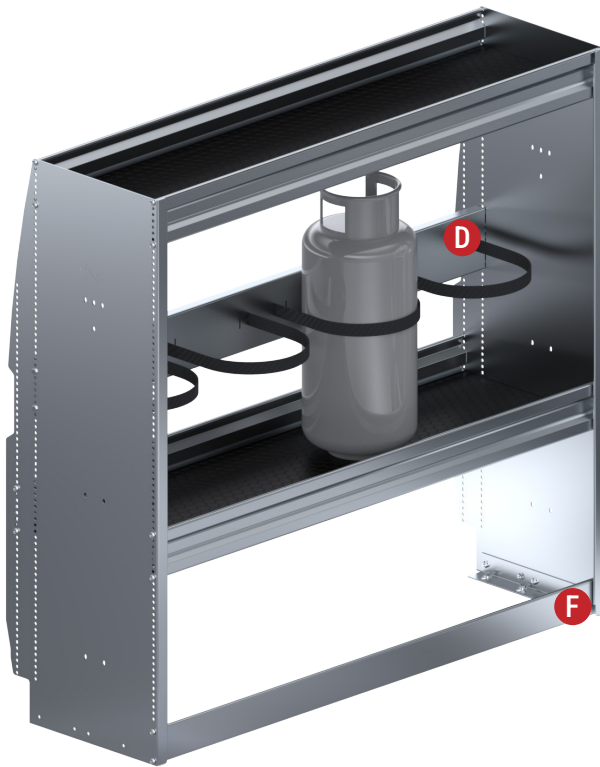

A – ALUMINUM DIVIDER KITS

PART #	QTY	COMPATIBLE SHELVING DEPTHS
33-1012	10 Pieces	12" D Shelving
* 33-1014	10 Pieces	14" D Shelving
33-1018	10 Pieces	18" D Shelving

B – LOCKING DOOR FRONT KITS

PART #	L	OPENING HEIGHT
* 33-1202	24"	12"
33-1203	36"	12"
33-1204	48"	12"
33-1205	60"	12"
33-1502	24"	15"
33-1503	36"	15"
33-1504	48"	15"
33-1505	60"	15"

C – IN SHELF AND UNDER SHELF DRAWER UNITS

PART #	L	D	H	DESCRIPTION
40-1340	46"	14 1/4"	7 3/8"	Under Shelf Side by Side 2 Drawer Unit for 48" L Shelving Unit
* 40-1350	34"	14 1/4"	7 3/8"	Under Shelf Side by Side 2 Drawer Unit for 36" L Shelving Unit
40-1360	58"	14 1/4"	7 3/8"	Under Shelf Side by Side 2 Drawer Unit for 60" L Shelving Unit
40-1380	36"	12 3/4"	6"	Under Shelf Single Drawer Unit for 36" L Shelving Unit
40-1210	22 7/8"	14"	12 1/8"	In Shelf 2 Drawer Unit
40-1230	22 7/8"	14"	15 1/8"	In Shelf 2 Drawer Unit

D – FREON TANK MOUNTING KITS

PART #	L	D	H	DESCRIPTION
52-3600	36"	1"	5"	3 Place In Shelf & Wall Mounted 30 lb Freon Tank Mounting Kit
* 52-4800	48"	1"	5"	4 Place In Shelf & Wall Mounted 30 lb Freon Tank Mounting Kit
52-6000	60"	1"	5"	5 Place In Shelf & Wall Mounted 30 lb Freon Tank Mounting Kit

E – SHELF BACK KITS

PART #	L	H	PART #	L	H
* 33-1224	24"	12"	33-1524	24"	15"
33-1236	36"	12"	33-1536	36"	15"
33-1248	48"	12"	33-1548	48"	15"
33-1260	60"	12"	33-1560	60"	15"

F – RETAINER LIP KITS

PART #	L	H	PART #	L	H
33-2400	24"	3"	33-7200	72"	3"
* 33-3600	36"	3"	33-8400	84"	3"
33-4800	48"	3"	33-9600	96"	3"
33-6000	60"	3"			

G – MID-SHELF BARRIER KITS

PART #	D	H	PART #	D	H
33-1212	10" - 12"	12"	33-1512	10" - 12"	15"
* 33-1214	12" - 14"	12"	33-1514	12" - 14"	15"

Under Shelf

In Shelf

VAN ACCESSORIES

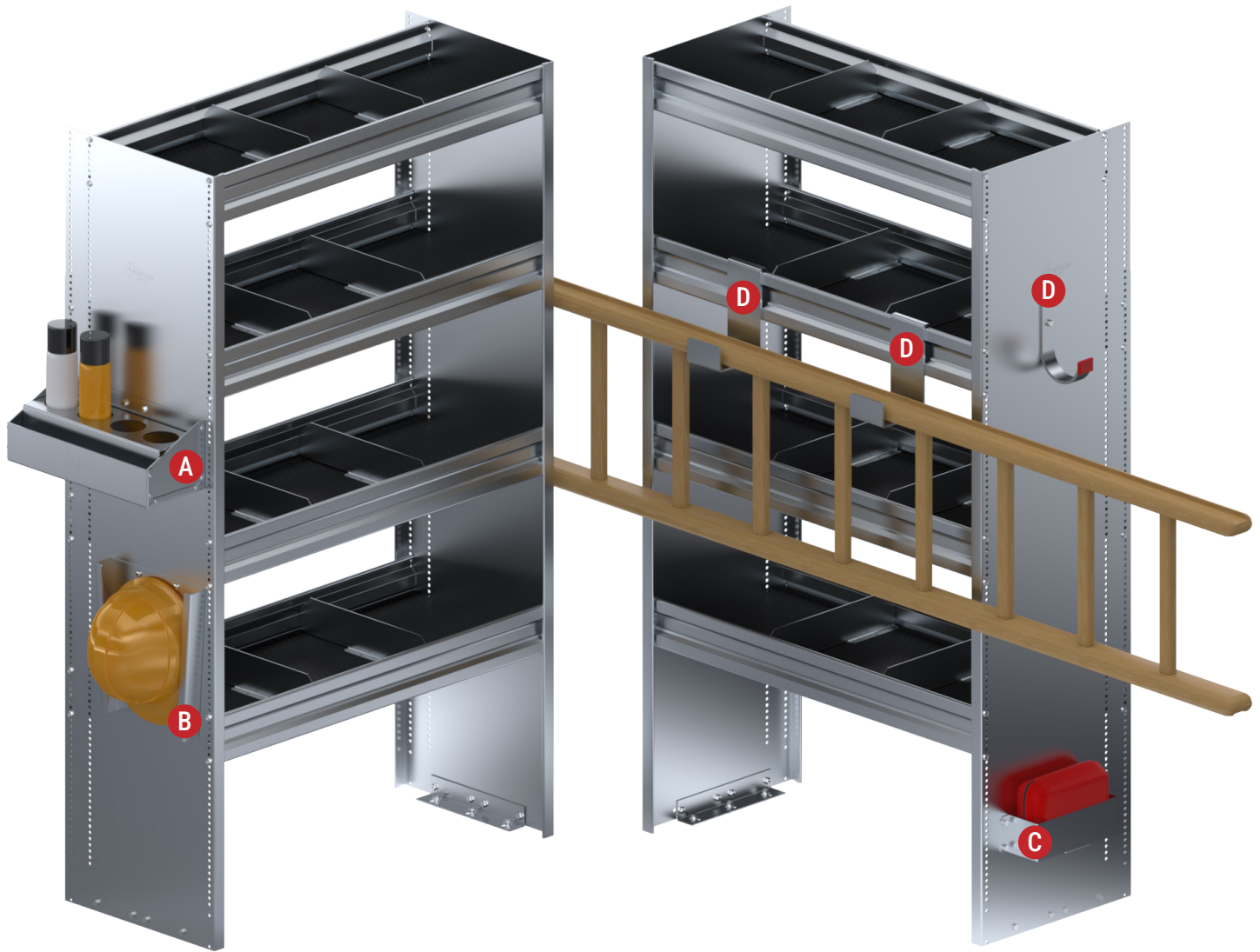

A – AEROSOL CAN HOLDER KITS

PART #	DESCRIPTION
63-1003	2 Place Spray Can Holder
* 63-1004	4 Place Spray Can Holder

B – HARD HAT HOLDER KIT

PART #	L	D	H	DESCRIPTION
* 63-1011	9"	2"	12"	Hard Hat Holder

C – MEDICAL KIT HOLDER KITS

PART #	L	D	H	INNER DIMENSIONS
63-1009	17 ³ / ₈ "	4 ⁷ / ₈ "	7 ¹ / ₈ "	15 ¹ / ₄ " L x 4 ⁵ / ₈ " D x 7" H
* 63-1010	10 ¹ / ₂ "	3 ¹ / ₈ "	3 ¹ / ₈ "	8 ¹ / ₂ " L x 2 ⁷ / ₈ " D x 3" H

D – HOOKS AND HANGER KITS

PART #	L	D	H	DESCRIPTION
65-1001	3 ³ / ₈ "	8 ⁷ / ₁₆ "	4 ⁹ / ₁₆ "	Shelf Mounted Ladder Hanger Pair
65-1002	1 ¹ / ₂ "	5 ¹ / ₄ "	7 ¹ / ₂ "	Single Swivel Hook (4 ¹ / ₂ " Opening)
65-1005	3 ¹ / ₂ "	4 ¹ / ₂ "	7"	Single Shelf Hanger (4 ¹ / ₂ " Opening)
65-1007	1 ¹ / ₄ "	5 ¹ / ₄ "	7 ¹ / ₂ "	Fixed Hook (4 ¹ / ₂ " Opening)
3001200	3 ³ / ₈ "	14"	6 ⁵ / ₈ "	3 Hook Hanger
3001300	6 ³ / ₈ "	7"	7 ¹ / ₂ "	2 Hook Shovel and Rake Holder

VAN ACCESSORIES

UNIVERSAL TRAFFIC CONE HOLDER KIT

PART #	DESCRIPTION
* 4001800	Traffic Cone Holder

Traffic Cone Holder Kit

Universal traffic cone holders can be mounted to your bumper! Made of aluminum, traffic cone holders are a low-cost solution which helps you keep your safety gear where you need it! The traffic cone holder has a maximum load rating of 35 lbs.

RECEIVER STEPS

PART #	DESCRIPTION
63-1005	24" L Straight Receiver Step
63-1006	24" L 4" Drop Receiver Step
* 63-1013	28 7/8" L Double Fold-Up Step

Receiver Steps

All receiver steps mount into a 2" trailer hitch receiver and have a maximum load capacity of 275 lbs! The double fold-up step can easily be folded up when in transit.

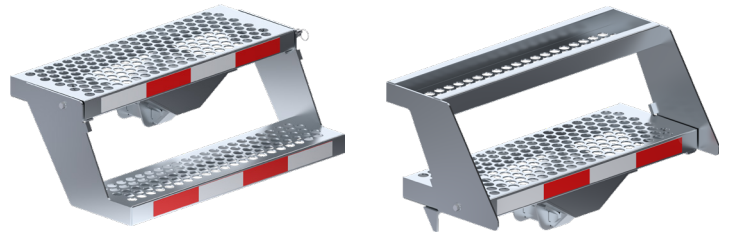

Adjustable Leg Feature

The legs on Westcan's data file cabinets are adjustable to allow to be mounted level on an uneven surface.

Did You Know?

Westcan's data file cabinet cup holder can be mounted to either the front or the back of the data file cabinet.

DATA FILE CABINET & CUP HOLDER KITS

PART #	L	D	H	DESCRIPTION
* 42-1600	10 1/2"	18"	16"	Data File Cabinet with Adjustable Legs
42-1630	8 3/4"	18"	16"	Data File Cabinet with Adjustable Legs
* 63-1012	11"	6 1/4"	5 1/2"	Data File Cabinet Cup Holder

DRAWER CABINETS

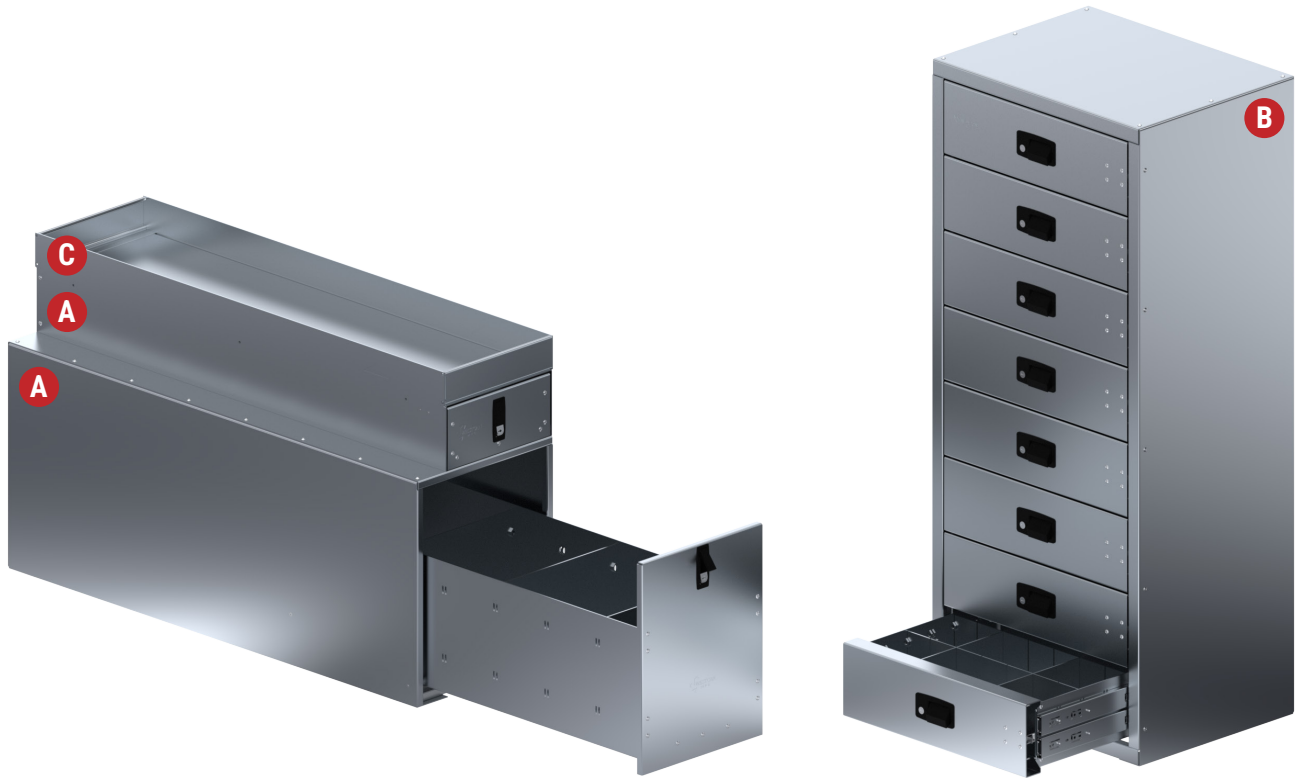

A – STACKABLE SINGLE DRAWER CABINETS

PART #	L	D	H	DESCRIPTION	FITS
* 40-1010	16"	48"	20"	Single Drawer Cabinet – 16" x 48"	→
40-1020	16"	36"	20"	Single Drawer Cabinet – 16" x 36"	→
40-1030	14"	48"	16"	Single Drawer Cabinet – 14" x 48"	→
* 40-1040	12"	48"	6"	Single Drawer Cabinet – 12" x 48"	→
40-1050	14"	36"	16"	Single Drawer Cabinet – 14" x 36"	→
40-1060	12"	36"	6"	Single Drawer Cabinet – 12" x 36"	→

C – TOP TRAY KITS

PART #	L	D	H	DESCRIPTION
40-1015	16"	48"	3"	Top Tray Kit – 16" x 48"
40-1025	16"	36"	3"	Top Tray Kit – 16" x 36"
40-1035	14"	48"	3"	Top Tray Kit – 14" x 48"
* 40-1045	12"	48"	3"	Top Tray Kit – 12" x 48"
40-1055	14"	36"	3"	Top Tray Kit – 14" x 36"
40-1065	12"	36"	3"	Top Tray Kit – 12" x 36"

B – MULTI-DRAWER CABINETS

PART #	L	D	H	DESCRIPTION	FITS
40-1110	15"	15"	24"	4 Drawer Cabinet – 15" x 15"	→
40-1120	24"	15"	24"	4 Drawer Cabinet – 24" x 15"	→
40-1130	37 5/8"	18 1/8"	47 1/4"	6 Drawer Cabinet – 37 5/8" x 18 1/8"	→
* 40-1140	24 3/8"	18 3/8"	56 1/4"	8 Drawer Cabinet – 24 3/8" x 18 3/8"	→
40-1150	18 1/4"	18 1/4"	35 1/2"	4 Drawer Cabinet – 18 1/4" x 18 1/4"	→
40-1170	18"	18"	28"	6 Drawer Cabinet - 18" x 18"	→

C – TOP TRAY KITS

PART #	L	D	H	DESCRIPTION
40-1115	15"	15"	4 1/2"	Top Tray Kit – 15" x 15"
40-1125	23 1/2"	15"	4"	Top Tray Kit – 23 1/2" x 15"
40-1135	37 7/8"	17 1/2"	4"	Top Tray Kit – 37 7/8" x 17 1/2"
40-1145	24"	18"	4"	Top Tray Kit – 24" x 18"
40-1155	18"	18"	4"	Top Tray Kit – 18" x 18"
40-1175	18 1/4"	18 1/4"	4 1/2"	Top Tray Kit – 18 1/4" x 18 1/4"

Drawer Cabinets

Westcan offers a wide variety of drawer cabinets to suit your storage needs! Whether you require in-shelf or standalone storage, we've got an option for you. All drawer cabinets are manufactured using marine grade aluminum and are fitted with ball bearing drawer slides for consistently smooth drawer usage. Westcan's aluminum drawer cabinets come with individual locking drawers and removable aluminum dividers. Need even more storage? Add a top tray for extra storage!

- Large single drawer units 40-1010, 40-1020, 40-1030, 40-1050 rated at 350 lbs.
- Available in premium heavy-duty keyed locking rated at 100 lbs per drawer.
- Light-duty drawer cabinets non keyed locking rated at 20 lbs per drawer.

ALUMINUM FOLD UP SHELVING UNITS



Features & Benefits of Fold Up Shelving Units

- Easily folds up to make room for larger cargo or to stow away when not in use
- Maximum load rating of 55 lbs per linear foot up to a maximum of 250 lbs per shelf
- Shelf decks are constructed using a durable 1/2"-thick honeycomb textured phenolic plywood base with extruded aluminum lips



Did You Know?

When building your own fold up shelving unit, please be aware of the depth of your shelves so there is enough clearance to stow in a fold up position.

FOLD UP SHELVING UNITS FOR CUBE VAN & TRAILER

PART #	L	D	H	SHELF QTY	SHELF DEPTHS
67-1041	31"	19 1/2"	62"	2 Shelves	1 @ 14", 1 @ 18" x 24"
67-1001	43"	19 1/2"	62"	2 Shelves	1 @ 14", 1 @ 18" x 36"
67-1002	55"	19 1/2"	62"	2 Shelves	1 @ 14", 1 @ 18" x 48"
67-1003	67"	19 1/2"	62"	2 Shelves	1 @ 14", 1 @ 18" x 60"
67-1004	79"	19 1/2"	62"	2 Shelves	1 @ 14", 1 @ 18" x 72"
67-1005	91"	19 1/2"	62"	2 Shelves	1 @ 14", 1 @ 18" x 84"
67-1006	43"	19 1/2"	62"	2 Shelves	2 @ 18" x 36"
67-1007	55"	19 1/2"	62"	2 Shelves	2 @ 18" x 48"
67-1008	67"	19 1/2"	62"	2 Shelves	2 @ 18" x 60"
67-1009	79"	19 1/2"	62"	2 Shelves	2 @ 18" x 72"
67-1010	91"	19 1/2"	62"	2 Shelves	2 @ 18" x 84"
67-1043	31"	21 1/2"	62"	2 Shelves	1 @ 18", 1 @ 20" x 24"

PART #	L	D	H	SHELF QTY	SHELF DEPTHS
67-1011	43"	21 1/2"	62"	2 Shelves	1 @ 18", 1 @ 20" x 36"
67-1012	55"	21 1/2"	62"	2 Shelves	1 @ 18", 1 @ 20" x 48"
67-1013	67"	21 1/2"	62"	2 Shelves	1 @ 18", 1 @ 20" x 60"
67-1014	79"	21 1/2"	62"	2 Shelves	1 @ 18", 1 @ 20" x 72"
67-1015	91"	21 1/2"	62"	2 Shelves	1 @ 18", 1 @ 20" x 84"
67-1044	31"	21 1/2"	62"	2 Shelves	2 @ 20" x 24"
67-1016	43"	21 1/2"	62"	2 Shelves	2 @ 20" x 36"
67-1018	55"	21 1/2"	62"	2 Shelves	2 @ 20" x 48"
67-1019	67"	21 1/2"	62"	2 Shelves	2 @ 20" x 60"
67-1020	79"	21 1/2"	62"	2 Shelves	2 @ 20" x 72"
67-1021	91"	21 1/2"	62"	2 Shelves	2 @ 20" x 84"
67-1045	31"	21 1/2"	72"	3 Shelves	1 @ 14", 1 @ 18", 1 @ 20" x 24"

BUILD YOUR OWN FOLD UP SHELVING UNIT

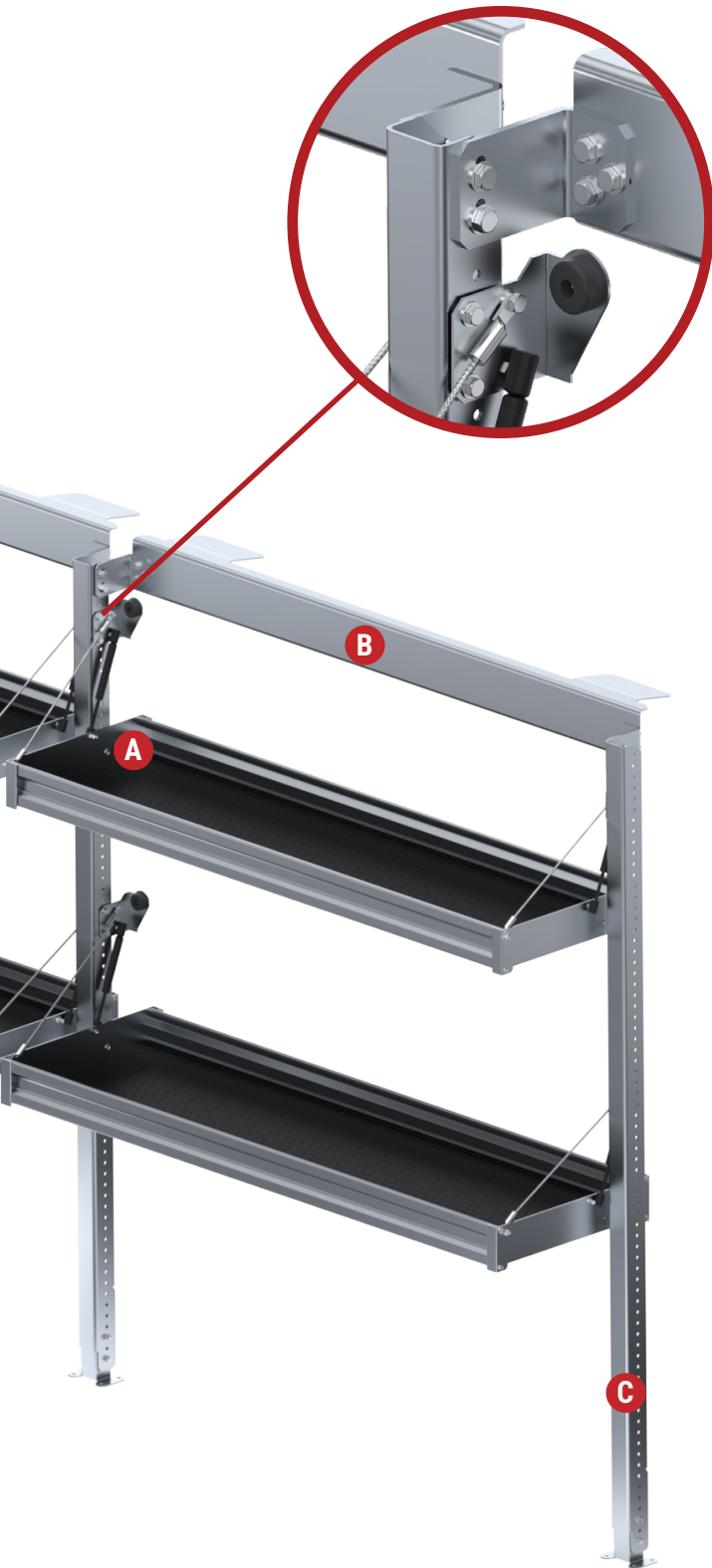

Tandem Fold Up Shelving

These can share a center leg which allows the tandem fold up shelving unit to be more compact allowing you to make the most of your cargo van space and save money on fold up shelving parts.

A – SINGLE FOLD UP SHELF KITS

	PART #	L	D		PART #	L	D
14" D Shelves	67-3020	24"	14"	18" D Shelves	67-3021	24"	18"
	67-3001	36"	14"		67-3006	36"	18"
	67-3002	48"	14"		67-3007	48"	18"
	67-3003	60"	14"		67-3008	60"	18"
	67-3004	72"	14"		67-3009	72"	18"
	67-3005	84"	14"		67-3010	84"	18"
20" D Shelves	67-3022	24"	20"				
	67-3011	36"	20"				
	67-3012	48"	20"				
	67-3013	60"	20"				
	67-3014	72"	20"				
	67-3015	84"	20"				

B – UPPER MOUNTING BRACKET KITS

PART #	L	D	PART #	L	D
67-5015	24"	1 7/8"	67-5010	60"	1 7/8"
67-5008	36"	1 7/8"	67-5011	72"	1 7/8"
67-5009	48"	1 7/8"	67-5012	84"	1 7/8"

C – SINGLE LEG KITS

PART #	L	H
67-5013	2 1/4"	46"
67-5004	2 1/4"	62"
67-5005	2 1/4"	72"

Build Your Own Fold Up Shelving Unit

Please refer to the table below when building your own fold up shelving unit. Ensure that all shelf kits and upper mounting brackets are the same length when ordering.

SINGLE FOLD UP SHELVING UNIT

TANDEM FOLD UP SHELVING UNIT

Single Fold Up Shelf Kit – 2 Pieces

Single Fold Up Shelf Kit – 2 Pieces

Upper Mounting Bracket – 1 Piece

Upper Mounting Bracket – 2 Pieces

Single Leg Kits – 2 Pieces

Single Leg Kits – 3 Pieces

STORAGE SOLUTIONS



Did You Know?

Westcan parts tote holders have been redesigned and are now compatible with Milwaukee tote #48-22-8030!

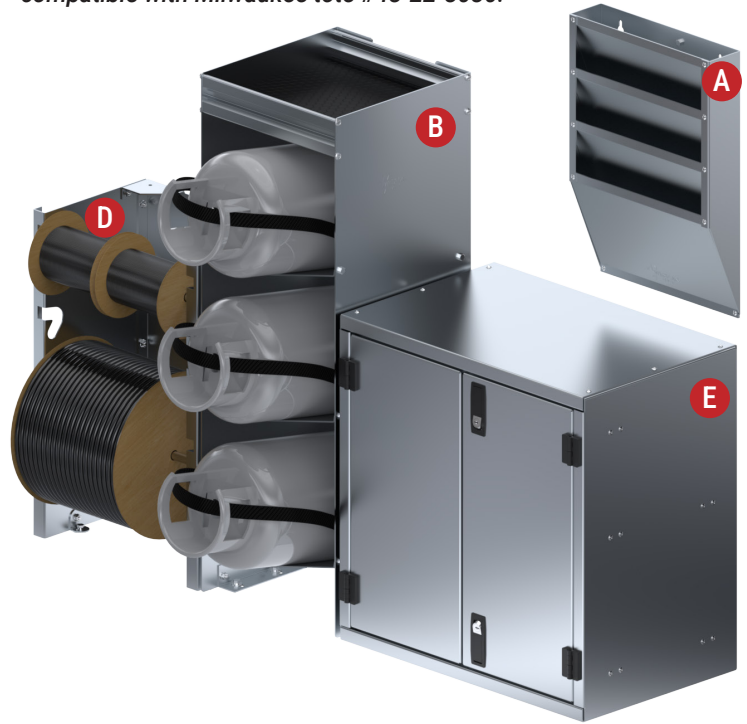

A – LITERATURE STORAGE

PART #	L	D	H	DESCRIPTION
50-1001	13 1/4"	4"	7 1/2"	1 Place Literature Storage
50-1003	13 1/4"	6 3/4"	15"	3 Place Literature Storage
50-1004	13 3/4"	3 1/4"	20"	4 Place Literature Storage
50-1005	15 1/4"	5 5/8"	24"	3 Place Literature & Binder Storage
50-6204	10"	13"	62"	4 Level Literature Storage

B – STANDALONE FREON TANK STORAGE

PART #	L	D	H	DESCRIPTION
52-6100	13"	13"	38"	3 Place 30 lbs Freon Tank Storage
52-6200	13"	13"	62"	5 Place 30 lbs Freon Tank Storage

C – PARTS TOTE HOLDERS & PLASTIC PARTS TOTES

PART #	L	D	H	DESCRIPTION
51-6201	17 3/4"	14"	5"	1 Place Parts Tote Holder (Fits Stanley Tote Only)
51-6203	19 5/8"	14"	25"	3 Place Parts Tote Holder
51-6205	19 5/8"	14"	35 1/2"	5 Place Parts Tote Holder
51-6208	19 5/8"	13 3/8"	62"	8 Place Parts Tote Holder
51-6209	19 7/8"	13 1/2"	46"	8 Place Parts Tote Holder Low Profile

Parts Tote Holders

D – SPOOL HOLDERS

PART #	L	D	H	DESCRIPTION
51-3000	14"	10"	48"	4 Place Spool Holder
51-3001	14"	10"	24"	2 Place Spool Holder

E – CABINETS

PART #	L	D	H	DESCRIPTION
42-1530	23 1/2"	15"	20"	2 Door Wedge Cabinet
42-1550	20"	15"	20"	Single Door Cabinet
42-1570	24"	15"	24"	2 Door Cabinet w/ Adjustable Shelf

F – CYLINDER STORAGE

PART #	L	D	H	DESCRIPTION
54-1000	5 1/4"	2 1/2"	12"	Fire Extinguisher Mount (Fits 4"-5" Diameter)
54-1010	6"	2 1/2"	12"	Cylinder Mount (Fits 5"-10" Diameter)
54-1020	9"	2 1/2"	12"	Cylinder Mount (Fits 10"-15" Diameter)

G – GARMENT LOCKERS

PART #	L	D	H	DESCRIPTION
41-4210	14 1/4"	15 1/2"	42"	Garment Locker
41-4610	14 1/4"	15 1/2"	46"	Garment Locker
41-4620	24 1/4"	15 1/2"	46"	Garment Locker
41-6210	14 1/4"	15 1/2"	62"	Garment Locker
41-6220	24 1/4"	15 1/2"	62"	Garment Locker

LIGHT-DUTY DRAWER CABINETS

Fits Seamlessly Into Westcan's Shelving Units.



40-1215

5 Drawer Cabinet

11 ³/₄ W x 13 ³/₄ H x 11 ³/₄ D

Drawer size

8 ¹/₂ W x 1 ¹/₂ H x 10 D



40-1225

5 Drawer Cabinet

23 ³/₄ W x 13 ³/₄ H x 11 ³/₄ D

Drawer size

20 ¹/₂ W x 1 ¹/₂ H x 10 D



40-1235

3 Drawer Cabinet

23 ³/₄ W x 13 ³/₄ H x 11 ³/₄ D

Drawer size

20 ¹/₂ W x 3 H x 10 D



40-1245

3 Drawer Cabinet

11 ³/₄ W x 13 ³/₄ H x 11 ³/₄ D

Drawer size

8 ¹/₂ W x 3 H x 10 D



CUB VAN, BOX TRUCK & ENCLOSED TRAILER

ALUMINUM PRODUCT GUIDE

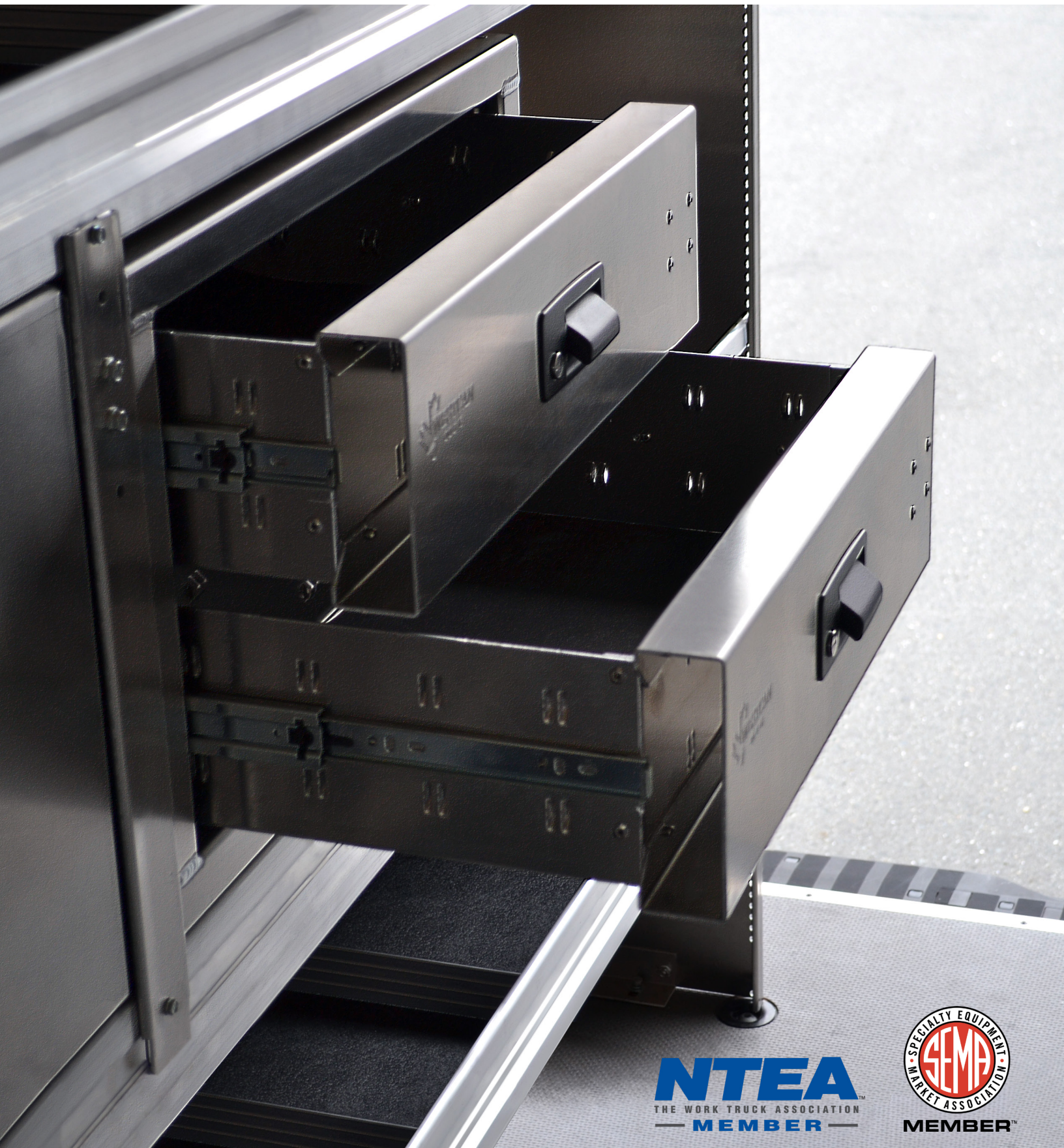

NTEA
THE WORK TRUCK ASSOCIATION
MEMBER

SPECIALTY EQUIPMENT
SEMA
MARKET ASSOCIATION
MEMBER